

ME3 SERIES

High Head (ME3H) and High Flow (ME3F)
Submersible Effluent Pumps

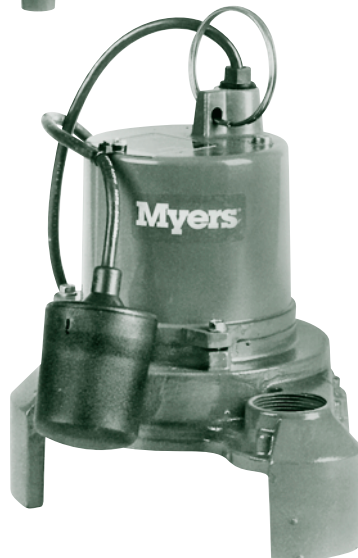

ME3F



ME3H



THE MYERS ME3 SERIES ARE RUGGED 1/3 HP EFFLUENT PUMPS DESIGNED FOR DEMANDING EFFLUENT PUMPING JOBS WHERE DEPENDABILITY IS A MUST. The ME3 is constructed of only the highest quality corrosion resistant materials - like cast iron, stainless steel and engineered thermoplastics - to provide many years of service in the harsh effluent environment. The ME3 is available with a recessed impeller for high-head applications or an enclosed impeller for high-flow applications - both will pass a full 3/4" spherical solid. The ME3 is available in automatic models with piggyback mechanical float switch or manual models for use with external controls. For more information, call your Myers distributor today or the Myers Ohio sales office at 419-289-6898.

ADVANTAGES BY DESIGN

DURABLE MOTOR WILL DELIVER MANY YEARS OF RELIABLE SERVICE.

- Oil-filled motor for maximum heat dissipation and continuous bearing lubrication.
- Overload protected, shaded pole motor eliminates starting switches and relays which are prone to fail.
- Heavy cast iron motor housing and volute case dissipate heat, allow motor to run cooler for extended life.

THE ME3 IS ENGINEERED FOR MANY YEARS OF MAINTENANCE-FREE OPERATION.

- Field tested, wide angle, mercury-free mechanical float switch for maximum draw down. (Automatic piggyback models only).
- Automatic pump models can be operated manually by unplugging piggyback switch and plugging pump directly into outlet.
- Passes a full 3/4" solid.

PRODUCT CAPABILITIES

| | | | |
|---------------------------|-------------------|---|--------------------|
| Capacities To | ME3H ME3F | 36 gpm 66 gpm | 136 lpm 250 lpm |
| Heads To | ME3H ME3F | 36 ft. 32 ft. | 11.0 m 9.75 m |
| Solids Handling Capacity | | 3/4 in. | 19 mm |
| Liquids Handling | | domestic effluent and drain water | |
| Intermittent Liquid Temp. | | up to 140°F | up to 60°C |
| Available Motors | | 1/3 hp, 1550 rpm shaded pole, oil-filled 115V, 11.5 amps, 1Ø, 60 Hz 230V, 5.8 amps, 1Ø, 60 Hz | |
| Third Party Approvals | | UL, CSA | |
| Acceptable pH Range | | 6 - 9 | |
| Specific Gravity | | .9 - 1.1 | |
| Viscosity | | 28 - 35 SSU | |
| Discharge, NPT | | 1½ in. | 50.8 mm |
| Min. Sump Dia. | Simplex Duplex | 24 in. 36 in. | 60.1 cm 91.4 cm |

Construction Materials

| | |
|----------------------------|--|
| Motor Housing | cast iron, Class 30, ASTM A48 |
| Impeller ME3H ME3F | engineered thermoplastic recessed enclosed |
| Impeller Wear Ring (ME3F) | 304 SST |
| Volute | cast iron, Class 30, ASTM A48 |
| Volute Sealing Ring (ME3F) | Buna-N |
| Power Cord | 10 or 20 ft., 16/3 SJTW/SJTW-A |
| Mechanical Shaft Seals | carbon and ceramic |
| Fasteners | 300 Series SST |

WHERE INNOVATION MEETS TRADITION

Myers[®]

Pentair Water

MECHANICAL FLOAT SWITCH

Mercury-free, 90° angle operation. (Piggyback models only)

POWER CORD
Quick-disconnect watertight fitting.

MOTOR HOUSING
Heavy cast iron for efficient heat transfer.

OVERLOAD SWITCH
Built-in to protect against over current and over temperature conditions.

THRUST WASHER, SLEEVE BEARINGS
Enhance smooth operation and extend pump life.

1/3 HP MOTOR
1550 RPM, 60 Hz, shaded pole design eliminates starting switch or relay mechanism. Pressed in place and oil-filled for best alignment and heat transfer.

VOLUTE CASE
Cast iron 1-1/2" discharge. Open design allows unobstructed passage of 3/4" solids.

VOLUTE/IMPELLER SEAL RING (ME3F)
Maintains high efficiency and reduces recirculation, replaceable.

MECHANICAL SHAFT SEAL
Carbon and ceramic faces. Body is stationary; prevents string or trash from winding on seal.

ENCLOSED TWO VANE IMPELLER (ME3F)
High efficiency, passes 3/4" spherical solids, with stainless steel wear ring.

RECESSED IMPELLER (ME3H)
Operates out of volute passage, allowing maximum flow of liquids and solids up to 3/4" diameter.

DIMENSIONS

ME3F

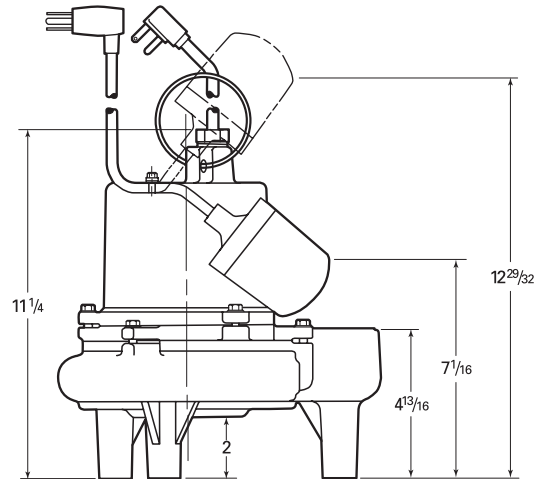
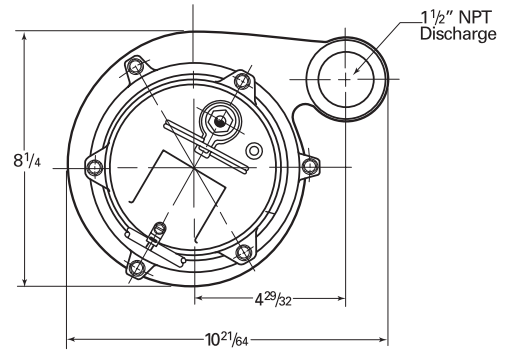

ME3H

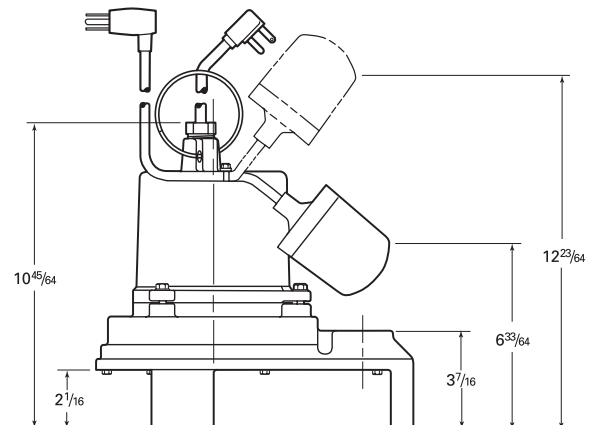
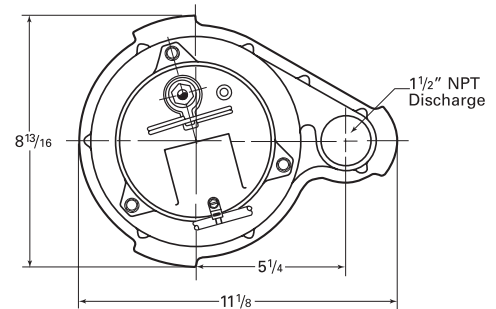

PUMP PERFORMANCE

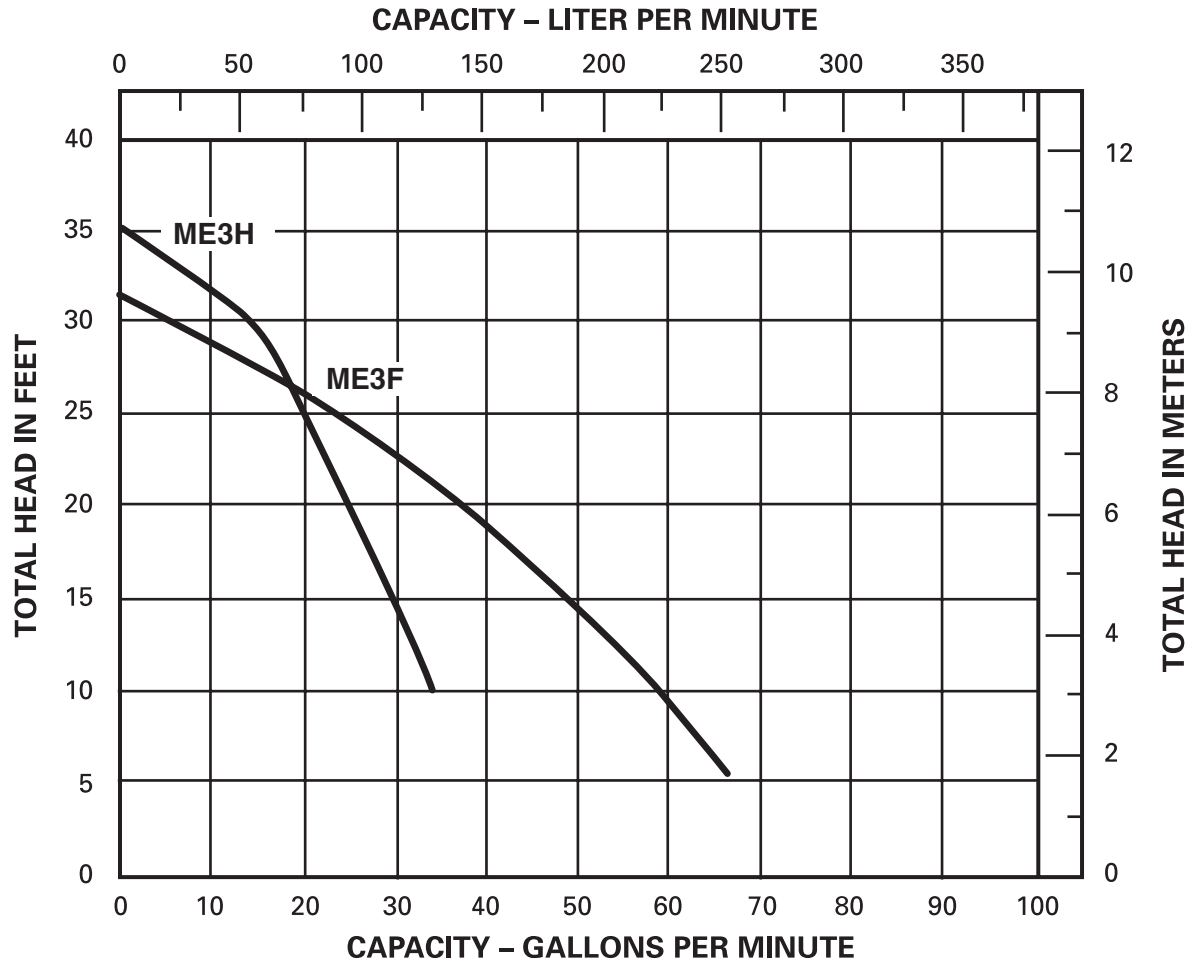

ME3 SERIES

SPECIFICATIONS

EFFLUENT PUMPS - Pump(s) shall be F. E. Myers ME3F / ME3H series sump pumps selected in accordance with the following design criteria:

| | |
|------------------------|---|
| Number of Pumps: | _____ |
| Primary Design Flow: | _____ |
| Primary Design Head: | _____ |
| Minimum Shut-off Head: | 36' |
| Motor Horsepower: | 1/3 |
| Motor Speed: | 1550 RPM |
| Electrical: | 115 Volts, 1 Ph, 60 Hz or 230 Volts, 1 Ph, 60 Hz |

PUMP - The pump shall be designed to handle septic tank effluent and be capable of passing 3/4 inch spherical solids. The pump shall be capable of handling liquids with temperatures to 140°F intermittent.

MOTOR - The pump motor shall be of the submersible type rated 1/3 hp at 1550 RPM and shall be for _____115 volts or _____230 volts single phase, 60 cycles. Single phase motor shall be of the shaded pole type with no relays or starting switches. Stator winding shall be of the open type with Class A insulation rated for 105°C maximum operating temperature. The winding housing shall be filled with clean dielectric oil to lubricate bearings and seals, and transfer heat from the windings to the outer shell. The motor winding assembly shall be pressed into the stator housing for best alignment and heat transfer.

The motor shall be capable of operating over the full range of the performance curve without overloading the motor and causing any objectionable noise or vibration. The motor shall have two bearings to support the rotor; an upper sleeve bearing to accommodate radial loads and a lower sleeve bearing with thrust pad to take thrust and radial loads.

A heat sensor thermostat and overload shall be attached to the top end of the motor windings and shall be wired in series with the windings to stop the motor if the motor winding temperature reaches 221°F. The overload thermostat shall reset automatically when the motor cools to a safe operating temperature.

POWER CORD - The motor power cord shall be _____10 or _____20 feet SJTW type. The cord shall have a molded compression grommet to insulate electrical connections. The grommet shall thread into the motor housing to provide a positive seal and to prevent leaking of liquid into the motor housing. The sealing grommet shall provide strain relief for the power cord assembly.

OPTIONAL CONTROL SWITCH - The effluent pump shall be controlled by an optional piggyback float switch. The float switch shall be of the mechanical, non-mercury type and be capable of directly controlling the pump motor without the need for an external control panel.

SHAFT SEAL - The motor shall be protected by a rotating mechanical shaft seal. The seals shall have carbon and ceramic seal faces lapped to a tolerance of one light band. Metal parts and springs for seals shall be 300 series stainless steel.

PUMP IMPELLER (ME3F) - The pump impeller shall be of the two vane enclosed type. The impeller shall be constructed of engineered thermoplastic. A stainless steel wear ring shall be molded into the neck of the impeller to provide a sealing surface. A replaceable Buna-N sealing cup shall effect a seal between the volute and impeller in order to maintain high efficiency and prevent recirculation.

PUMP IMPELLER (ME3H) - The pump impeller shall be of the recessed type. The impeller shall be constructed of engineered thermoplastic.

MOTOR CASTINGS - The motor housing castings shall be of high tensile strength Class 30 gray cast iron. Castings shall be treated with phosphate and chromate rinse and painted with a high quality air dry alkyd enamel for corrosion protection.

PUMP CASE - The pump case shall be a high efficiency volute design capable of passing 3/4 inch spherical solids. The pump volute shall be constructed of Class 30 gray cast iron.

FASTENERS - All exposed fasteners shall be of 300 series stainless steel.