

# 6VCDP and 6VCXDP

## Submersible Dry Pit

6" Non-Clog Wastewater Pumps  
Standard (6VCDP) and Explosion-Proof (6VCXDP)

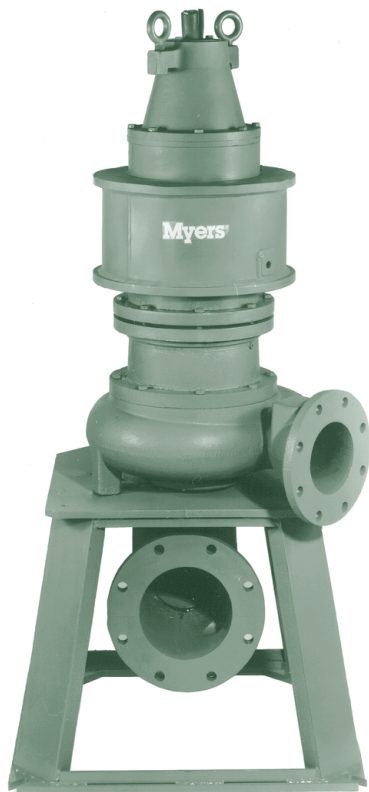

**T**HE 6VCDP AND 6VCXDP (EXPLOSION-PROOF) SUBMERSIBLE DRY PIT WASTEWATER PUMPS ARE A HEAVY-DUTY 6" NON-CLOG SERIES CAPABLE OF PASSING A FULL 3<sup>3</sup>/<sub>16</sub>" SPHERICAL SOLID. Myers rounded port, 2-vane, enclosed impellers prevent solids from binding or clogging and offer high operating efficiencies to cut your pumping costs. The 6VCDP series modified constant velocity volute case provides smooth operation over an extended portion of the performance curve for longer seal and bearing life. For use in municipal and industrial waste applications. Myers offers a complete line of submersible dry pit wastewater pumps, controls and accessories to meet your needs. Call your Myers distributor, or the Myers Ohio sales office at 419-289-1144 for more details.

### ADVANTAGES BY DESIGN

**HIGH EFFICIENCY HYDRAULIC DESIGN CUTS PUMPING COSTS AND EXTENDS LIFE OF FLUID END COMPONENTS.**

- Two-vane, rounded port, enclosed type impeller handles 3<sup>3</sup>/<sub>16</sub>" solids with ease at high operating efficiencies.
- Modified constant velocity volute offers quiet operation, low radial loads over extended portion of performance curve.

### DURABLE MOTOR WILL DELIVER MANY YEARS OF RELIABLE SERVICE

- Class H insulation.
- Continuous duty/VFD magnet wire.
- Oil-filled motor for maximum heat dissipation and constant bearing lubrication.
- Heat sensor thermostats imbedded in windings protect motor from over heat conditions.
- Seal leak probes warn of moisture entry; helps prevent costly motor burnout.
- Double tandem shaft seals prevent sewage from entering motor.
- Power and control cables are triple sealed with epoxy, compression grommet and terminal board.

**AVAILABLE WITH OPTIONAL F.M. APPROVAL FOR USE IN CLASS 1, GROUPS C AND D HAZARDOUS LOCATIONS (6VCXDP Only).**

### PRODUCT CAPABILITIES

Capacities To	2400 gpm	151.2 lps
Heads To	146 ft.	44.5 m
Solids Handling	3 <sup>3</sup> / <sub>16</sub> in.	80 mm
Liquids Handling	raw unscreened sewage, effluent, storm water	
Intermittent Liquid Temp.	up to 140°F	up to 60°C
Winding Insulation Temp. (Class H)	356°F	180°C
Available Motors	<b>1750 RPM:</b> 15-60 HP 230/460/575V 3Ø, 60 Hz. <b>1150 RPM:</b> 5-20 HP 200/230/460/575V, 3Ø 60 Hz. <b>870 RPM:</b> 2-7½ HP 200/230/460/575V, 3Ø, 60 Hz	
Std. Third Party Approvals	CSA (pending)	
Optional Approvals	FM Class 1, Groups C & D (pending - 6VCXDP only)	
Acceptable pH Range	6 - 9	
Specific Gravity	.9 - 1.1	
Viscosity	28 - 35 SSU	
Discharge, Horizontal Flanged Centerline	6 in. 125 lb. ANSI	152.4 mm

NOTE: Consult factory for applications outside of these recommendations.

Construction Materials	
Motor Housing, Seal Housing, Cord Cap and Volute Case	cast iron, Class30 ASTM A48
Enclosed 2-Vane Impeller	ductile iron, Class 65 ASTM A536
Power and Control Cord	25 ft. SOOW
Mechanical Seals	double tandem, type 21
Standard	carbon and ceramic
Optional	lower tungsten, carbide
Pump, Motor Shaft	416 SST
Fasteners	300 Series SST
Volute Wear Ring	brass
Base Elbow	cast iron, Class 30, ASTM A48

**WHERE INNOVATION MEETS TRADITION**

**Myers**<sup>®</sup>

Pentair Water

**POWER & CONTROL CORDS**

SOOW, FM and CSA approved oil-resistant cable.

**CABLE ENTRY SYSTEM**

Provides triple seal protection. Cable jacket sealed by compression grommet. Individual wires sealed by epoxy potting. Terminal board separates motor chamber from cord cap.

**HEAT SENSOR**

Protects motor from burn-out due to excessive heat from any overload condition. Automatically resets when motor has cooled.

**MOTOR STATOR**

Heat shrunk into housing for perfect alignment and best heat transfer. Oil-filled motor conducts heat and lubricates bearings. Class H insulation.

**BALL BEARINGS**

Upper and lower ball bearings support shaft and rotor and take axial and radial loads.

**SHAFT SEALS**

Double tandem mechanical shaft seals protect motor. Oil-filled seal chamber provides continuous lubrications.

**SEAL LEAK PROBES**

Detect water in seal housing. Activates warning light in control panel.

**HEAVY 416 SST SHAFT**

Corrosion resistant.

**SLEEVE BEARING**

Takes radial shock load; provides flame path.

**BRASS WEAR RING**

Prevents rust build-up and reduces leakage and wear. Replaceable to restore original running clearances and pump efficiencies.

**VOLUTE CASE**

Modified constant velocity volute handles 3<sup>3</sup>/<sub>16</sub>" solids. 6" ANSI 125 lb. flange.

**HIGH EFFICIENCY IMPELLER**

Two-vane with rounded ports. Handles 3<sup>3</sup>/<sub>16</sub>" solids. Pump out vanes help keep trash from seal; reduces pressure at seal faces.

**CLEAN-OUT PORT**

Easy access for servicing.

**DIMENSIONS**

[ ] Dimensions in mm

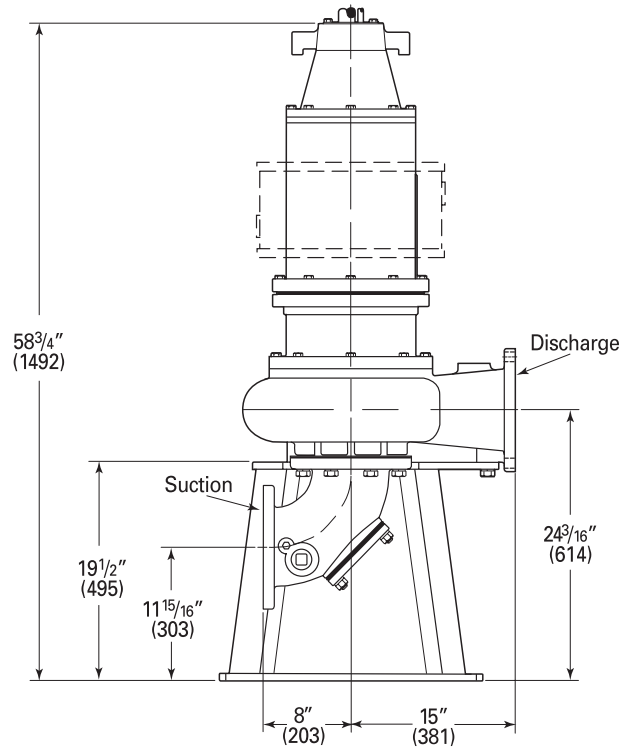

# PUMP PERFORMANCE

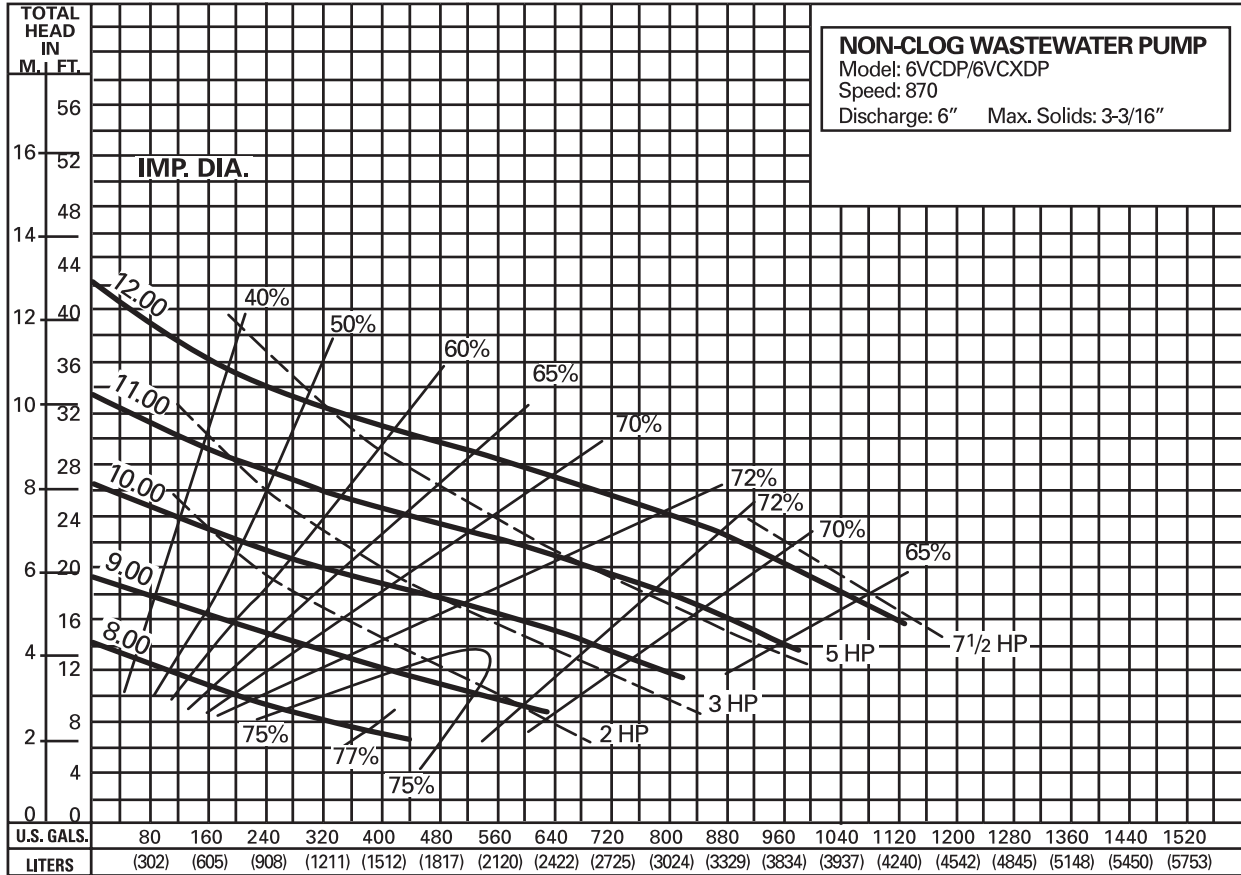

Pump performance is based on clear water (1.0 specific gravity @ 68°F) and pump fluid end (hydraulic) efficiency. Motor data based on 40°C ambient temperature.

Available Models		Motor Electrical Data											
Standard	Explosion Proof	HP	Volts	Phase	Start Amps	Run Amps	Service Factor Amps	Run KW	Service Factor KW	Start KVA	Run KVA	NEC Code Letter	Service Factor
6VCDP20M8-03	6VCXDP20M8-03	2	200	3	48.3	10.8	13	2.7	3.3	16.7	3.8	K	1.2
6VCDP20M8-23	6VCXDP20M8-23	2	230	3	42	9.5	11.4	2.7	3.3	16.7	3.8	K	1.2
6VCDP20M8-43	6VCXDP20M8-43	2	460	3	21	4.8	5.7	2.7	3.3	16.7	3.8	K	1.2
6VCDP20M8-53	6VCXDP20M8-53	2	575	3	16.8	3.8	4.6	2.7	3.3	16.7	3.8	K	1.2
6VCDP30M8-03	6VCXDP30M8-03	3	200	3	58.8	15.6	19	3.9	4.8	20.4	5.4	H	1.2
6VCDP30M8-23	6VCXDP30M8-23	3	230	3	51.1	13.7	16.6	3.9	4.8	20.4	5.4	H	1.2
6VCDP30M8-43	6VCXDP30M8-43	3	460	3	25.6	6.8	8.3	3.9	4.8	20.4	5.4	H	1.2
6VCDP30M8-53	6VCXDP30M8-53	3	575	3	20.4	5.4	6.6	3.9	4.8	20.4	5.4	H	1.2
6VCDP50M8-03	6VCXDP50M8-03	5	200	3	103.5	24.1	28.8	6.0	7.3	36.0	8.4	J	1.2
6VCDP50M8-23	6VCXDP50M8-23	5	230	3	90	21	25	6.0	7.3	36.0	8.4	J	1.2
6VCDP50M8-43	6VCXDP50M8-43	5	460	3	45	10.5	12.5	6.0	7.3	36.0	8.4	J	1.2
6VCDP50M8-53	6VCXDP50M8-53	5	575	3	36	8.4	10	6.0	7.3	36.0	8.4	J	1.2
6VCDP75M8-03	6VCXDP75M8-03	7.5	200	3	149	30.3	36.8	7.7	9.4	52.0	10.6	H	1.2
6VCDP75M8-23	6VCXDP75M8-23	7.5	230	3	130	26.4	32	7.7	9.4	52.0	10.6	H	1.2
6VCDP75M8-43	6VCXDP75M8-43	7.5	460	3	65	13.2	16	7.7	9.4	52.0	10.6	H	1.2
6VCDP75M8-53	6VCXDP75M8-53	7.5	575	3	52	10.6	12.8	7.7	9.4	52.0	10.6	H	1.2

Motor Efficiencies and Power Factor									
Motor Efficiency %						Power Factor %			
HP	Phase	Service Factor Load	100% Load	75% Load	50% Load	Service Factor Load	100% Load	75% Load	50% Load
2	3	73	72	67	59	72	71	65	55
3	3	74	73	69	62	73	72	66	57
5	3	83	81	76.5	67.5	73	72	66.5	58
7.5	3	83.5	82	77	69	74	73	68	60

NOTE: NO COOLING JACKET REQUIRED FOR ALL MODELS.

# PUMP PERFORMANCE

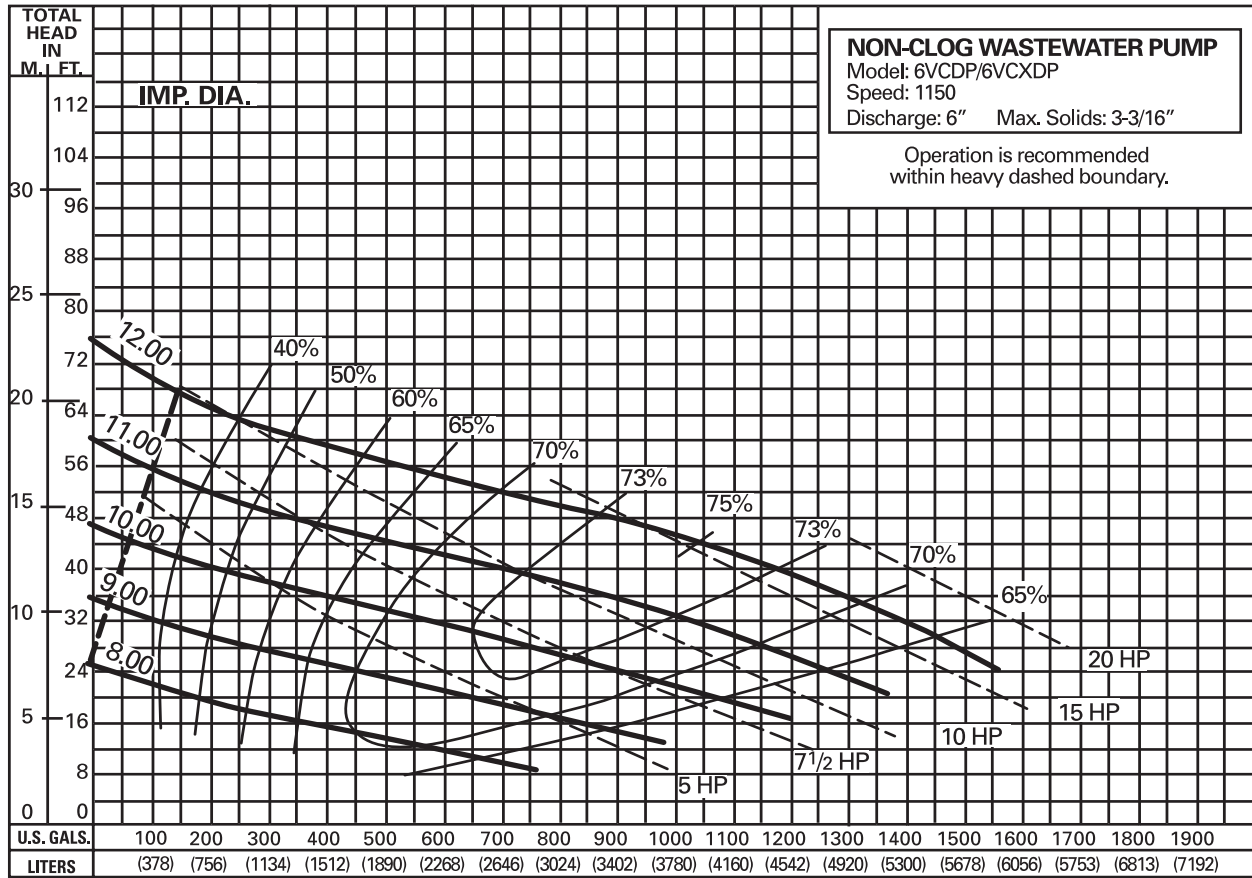

Pump performance is based on clear water (1.0 specific gravity @ 68°F) and pump fluid end (hydraulic) efficiency. Motor data based on 40°C ambient temperature.

Available Models		Motor Electrical Data											
Standard	Explosion Proof	HP	Volts	Phase	Start Amps	Run Amps	Service Factor Amps	Run KW	Service Factor KW	Start KVA	Run KVA	NEC Code Letter	Service Factor
6VCDP50M6-03	6VCXDP50M6-03	5	200	3	106	19.3	23	4.8	5.8	36.7	6.7	J	1.2
6VCDP50M6-23	6VCXDP50M6-23	5	230	3	92	16.8	20	4.8	5.8	36.7	6.7	J	1.2
6VCDP50M6-43	6VCXDP50M6-43	5	460	3	46	8.4	10	4.8	5.8	36.7	6.7	J	1.2
6VCDP50M6-53	6VCXDP50M6-53	5	575	3	37	6.7	8	4.8	5.8	36.7	6.7	J	1.2
6VCDP75M6-03	6VCXDP75M6-03	7.5	200	3	147	27	32.2	6.8	8.4	50.9	9.4	H	1.2
6VCDP75M6-23	6VCXDP75M6-23	7.5	230	3	128	23.6	28	6.8	8.4	50.9	9.4	H	1.2
6VCDP75M6-43	6VCXDP75M6-43	7.5	460	3	64	11.8	14	6.8	8.4	50.9	9.4	H	1.2
6VCDP75M6-53	6VCXDP75M6-53	7.5	575	3	51	9.4	11.2	6.8	8.4	50.9	9.4	H	1.2
6VCDP100M6-03	6VCXDP100M6-03	10	200	3	197	34.3	41.4	8.8	10.9	68.5	12.0	H	1.2
6VCDP100M6-23	6VCXDP100M6-23	10	230	3	172	30	36	8.8	10.9	68.5	12.0	H	1.2
6VCDP100M6-43	6VCXDP100M6-43	10	460	3	86	15	18	8.8	10.9	68.5	12.0	H	1.2
6VCDP100M6-53	6VCXDP100M6-53	10	575	3	69	12	14.4	8.8	10.9	68.5	12.0	H	1.2
6VCDP150M6-03	6VCXDP150M6-03	15	200	3	276	48	59.8	13.0	15.7	95.6	17.5	H	1.2
6VCDP150M6-23	6VCXDP150M6-23	15	230	3	240	44	52	13.0	15.7	95.6	17.5	H	1.2
6VCDP150M6-43	6VCXDP150M6-43	15	460	3	120	22	26	13.0	15.7	95.6	17.5	H	1.2
6VCDP150M6-53	6VCXDP150M6-53	15	575	3	96	17.6	20.8	13.0	15.7	95.6	17.5	H	1.2
6VCDP200M6-03	6VCXDP200M6-03	20	200	3	333	66.3	80.5	17.2	21.4	115.5	23.0	G	1.2
6VCDP200M6-23	6VCXDP200M6-23	20	230	3	290	58	70	17.2	21.4	115.5	23.0	G	1.2
6VCDP200M6-43	6VCXDP200M6-43	20	460	3	145	29	35	17.2	21.4	115.5	23.0	G	1.2
6VCDP200M6-53	6VCXDP200M6-53	20	575	3	116	23	28	17.2	21.4	115.5	23.0	G	1.2

Motor Efficiencies and Power Factor									
Motor Efficiency %					Power Factor %				
HP	Phase	Service Factor Load	100% Load	75% Load	50% Load	Service Factor Load	100% Load	75% Load	50% Load
5	3	82	81	77	68	74	72	66	56
7.5	3	84	83	79	71	75	73	66.5	56.5
10	3	87	86	82	75	76	74	67	57
15	3	88	88	86.5	82.5	76	74.5	68	57.5
20	3	88	88	87	83	77	75	69	59

NOTE: COOLING JACKET REQUIRED FOR 10, 15 and 20 HP MODELS

# PUMP PERFORMANCE

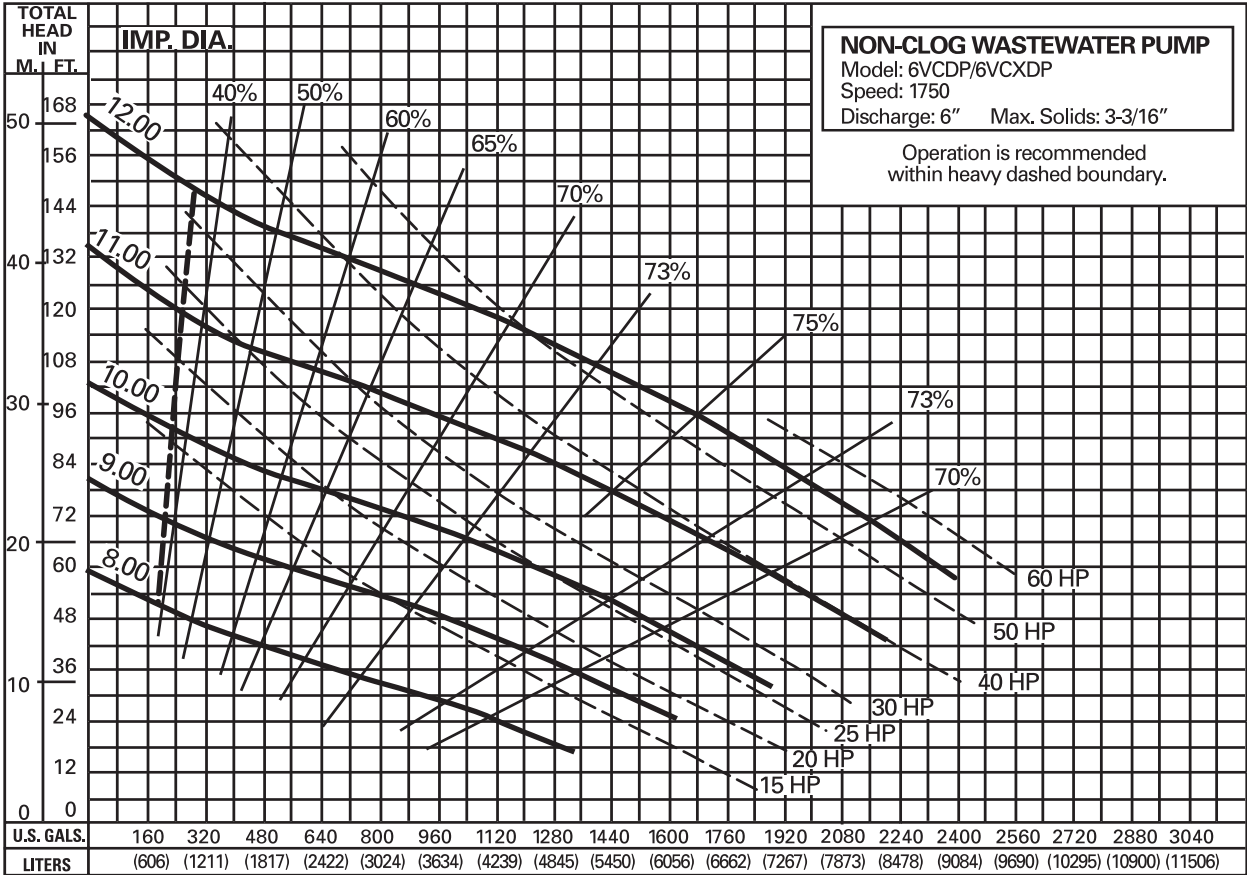

Pump performance is based on clear water (1.0 specific gravity @ 68°F) and pump fluid end (hydraulic) efficiency. Motor data based on 40°C ambient temperature.

Available Models		Motor Electrical Data												
Standard	Explosion Proof	HP	Volts	Phase	Hertz	Start Amps	Run Amps	Service Factor Amps	Run KW	Service Factor KW	Start KVA	Run KVA	NEC Code Letter	Service Factor
6VCDP150M4-03	6VCXDP150M4-03	15	200	3	60	215	50.6	61	15.0	18.6	74.5	17.5	E	1.2
6VCDP150M4-23	6VCXDP150M4-23	15	230	3	60	187	44	53	15.0	18.6	74.5	17.5	E	1.2
6VCDP150M4-43	6VCXDP150M4-43	15	460	3	60	93.5	22	26.5	15.0	18.6	74.5	17.5	E	1.2
6VCDP150M4-53	6VCXDP150M4-53	15	575	3	60	74.8	17.6	21.2	15.0	18.6	74.5	17.5	E	1.2
6VCDP200M4-23	6VCXDP200M4-23	20	230	3	60	290	60	72	21.2	26.1	115.5	23.9	G	1.2
6VCDP200M4-43	6VCXDP200M4-43	20	460	3	60	145	30	36	21.2	26.1	115.5	23.9	G	1.2
6VCDP200M4-53	6VCXDP200M4-53	20	575	3	60	116	24	28.8	21.2	26.1	115.5	23.9	G	1.2
6VCDP250M4-23	6VCXDP250M4-23	25	230	3	60	366	76	92	26.9	33.3	145.8	30.3	G	1.2
6VCDP250M4-43	6VCXDP250M4-43	25	460	3	60	183	38	46	26.9	33.3	145.8	30.3	G	1.2
6VCDP250M4-53	6VCXDP250M4-53	25	575	3	60	146	30.4	36.8	26.9	33.3	145.8	30.3	G	1.2
6VCDP300M4-23	6VCXDP300M4-23	30	230	3	60	452	94	114	33.3	41.3	180.1	37.4	G	1.2
6VCDP300M4-43	6VCXDP300M4-43	30	460	3	60	226	47	57	33.3	41.3	180.1	37.4	G	1.2
6VCDP300M4-53	6VCXDP300M4-53	30	575	3	60	181	37.6	45.6	33.3	41.3	180.1	37.4	G	1.2
6VCDP400M4-23	6VCXDP400M4-23	40	230	3	60	580	122	148	43.2	53.0	231.1	48.6	G	1.2
6VCDP400M4-43	6VCXDP400M4-43	40	460	3	60	290	61	74	43.2	53.0	231.1	48.6	G	1.2
6VCDP400M4-53	6VCXDP400M4-53	40	575	3	60	232	48.8	59.2	43.2	53.0	231.1	48.6	G	1.2
6VCDP500M4-23	6VCXDP500M4-23	50	230	3	60	580	134	158	46.9	54.6	231.1	53.4	E	1.2
6VCDP500M4-43	6VCXDP500M4-43	50	460	3	60	290	67	79	46.9	54.6	231.1	53.4	E	1.2
6VCDP500M4-53	6VCXDP500M4-53	50	575	3	60	232	54	63	46.9	54.6	231.1	53.4	E	1.2
6VCDP600M4-23	6VCXDP600M4-23	60	230	3	60	580	158	158	52.8	52.8	231.1	62.9	C	1.0
6VCDP600M4-43	6VCXDP600M4-43	60	460	3	60	290	79	79	52.8	52.8	231.1	62.9	C	1.0
6VCDP600M4-53	6VCXDP600M4-53	60	575	3	60	232	63	63	52.8	52.8	231.1	62.9	C	1.0

Motor Efficiencies and Power Factor									
		Motor Efficiency %				Power Factor %			
HP	Phase	Service Factor Load	100% Load	75% Load	50% Load	Service Factor Load	100% Load	75% Load	50% Load
15	3	85	84	79	69	88	86	78	68
20	3	88	87.5	81	72.5	91	89	79	69
25	3	87	86	81	73	91	89	80	70
30	3	87	86	83	79	91	89	82	73
40	3	86	86	88	87.5	90	89	86	80
50	3	87	86	86.5	88	87	88	88.5	84
60	3	87	87	86	88	84	84	89	86

NOTE: COOLING JACKET REQUIRED FOR ALL MODELS

# 6VCDP and 6VCXDP

---

## SPECIFICATIONS

**PUMP MODEL** – Pump shall be Myers Model Number 6VCDP / 6VCXDP Non-Clog Submersible Dry Pit Pump with 2 vane enclosed impeller. All openings in pump impeller and volute case to be large enough to pass a 3-3/16" diameter sphere. Discharge flange shall be six (6) inch standard. The pump and motor assembly shall be FM listed for Class 1, Groups C and D explosion-proof service (6VCXDP only).

The pump shall be fitted with a 6" x 6" or 6" x 8" suction elbow. A hand hole clean-out shall be provided on the suction elbow. A steel pump stand shall be provided.

**OPERATING CONDITIONS** – Pump shall have a capacity of \_\_\_\_\_ GPM at a total head of \_\_\_\_\_ feet and shall use a \_\_\_\_\_ HP motor operating at \_\_\_\_\_ RPM.

**MOTOR** – Pump motor shall be of the sealed submersible type rated \_\_\_\_\_ HP at \_\_\_\_\_ RPM 60 Hertz. Motor shall be for three phase 200 volts \_\_\_\_\_ 230 volts \_\_\_\_\_ 460 volts \_\_\_\_\_ or 575 volts \_\_\_\_\_. Motor shall be NEMA B type.

Stator winding shall be of the open type with Class H insulation good for 180°C maximum temperature. Winding housing shall be filled with a clean high dielectric oil that lubricates bearings and seals and transfers heat from winding and rotor to outer shell. Air-filled motors which do not have the superior heat dissipating capabilities of oil-filled motors shall not be considered equal.

The pump shall be suitable operating continuously at full load in a dry pit application with ambient temperature of 95°F. The pump shall also be capable of operating fully submersed without damage. The pump shall employ the use of a cooling jacket as needed.

Motor shall have two heavy duty ball bearings to support pump shaft and take radial and thrust loads and a sleeve guide bushing directly above the lower seal to take radial load and act as flame path for seal chamber. Ball bearings shall be designed for 50,000 hours B-10 life. Stator shall be heat shrunk into motor housing.

A heat sensor thermostat shall be attached to and imbedded in the winding and be connected in series with the motor starter contractor coil to stop motor if temperature of winding is more than 130°C. Thermostat to reset automatically when motor cools to safe operating temperature. Three heat sensors shall be used. The common pump, motor shaft shall be of 416 stainless steel.

**SEALS** – Motor shall be protected by two mechanical seals mounted in tandem with a seal chamber between the seals. Seal chamber shall be oil filled to lubricate seal face and to transmit heat from shaft to outer shell.

Seal face shall be carbon and ceramic and lapped to a flatness of one light band. Lower seal faces shall be \_\_\_\_\_ carbide (optional).

A double electrode shall be mounted in the seal chamber to detect any water entering the chamber through the lower seal. Water in the chamber shall cause a red light to turn on at the control box. This signal shall not stop motor but shall act as a warning only, indicating service is required.

**IMPELLER** – The impeller shall be ductile iron and of the 2 vane non-clog enclosed type. Vane inlet tips shall be carefully rounded to prevent stringy material from catching in vanes. Pump-out vane shall be used in front and back chamber. Impeller shall be dynamically balanced. Impeller shall be driven by stainless steel shaft key and impeller held in place with lock screw and washer. Impeller and motor shall lift off of case as a unit without disturbing discharge piping.

Impeller neck shall run in bronze wear ring that is pressed into volute case.

**PUMP CASE** – The volute case shall be cast iron and have a flanged center line discharge. Discharge flange shall be 6" standard with bolt holes straddling center line. A bronze wear ring shall be pressed into case for guiding impeller neck and to prevent corrosion freeze up. Wear ring to be held from rotating by locking with stainless steel set screw in end of ring.

**PUMP AND MOTOR CASTING** – All castings shall be of high tensile cast iron and shall be treated with phosphate and chromate rinse. All fasteners shall be 302 stainless steel.

**BEARING END CAP** – Upper motor bearing cap shall be a separate casting for easy mounting and replacement.

**POWER CABLES** – Power cord and control cord shall be triple sealed. The power and control conductor shall be single strand sealed with epoxy potting compound and then clamped in place with rubber seal bushing to seal outer jacket against leakage and to provide for strain pull. A third sealing area shall be provided by a terminal board to separate the cable entry chamber from the motor chamber. Cords shall withstand a pull of 300 pounds.

Insulation of power and control cords shall be type SOOW. Both control and power cords shall have a green carrier ground conductor that attaches to motor frame.