

# 6VH and 6VHX

6" Non-Clog Wastewater Pumps  
Standard (6VH) and Explosion-Proof (6VHX) Construction



(6VHX only)

**THE 6VH AND 6VHX (EXPLOSION-PROOF) SUBMERSIBLE WASTEWATER PUMPS ARE A HEAVY-DUTY 6" NON-CLOG SERIES CAPABLE OF PASSING A FULL 3" SPHERICAL SOLID.**

Myers rounded port, 2-vane, enclosed impellers prevent solids from binding or clogging and offer high operating efficiencies to cut your pumping costs. The 6VH series modified constant velocity volute case provides smooth operation over an extended portion of the performance curve for longer seal and bearing life. For use in municipal lift stations, treatment plants and industrial waste applications. Myers offers a complete line of wastewater pumps, lift-out rail assemblies, controls and accessories to meet your needs. Call your Myers distributor or the Myers Ohio sales office at 419-289-6898 for more details.

**ADVANTAGES BY DESIGN**

**HIGH EFFICIENCY HYDRAULIC DESIGN CUTS PUMPING COSTS AND EXTENDS LIFE OF FLUID END COMPONENTS.**

- Two-vane, rounded port, enclosed type impellers handle 3" solids with ease at high operating efficiencies.
- Modified constant velocity volute offers quiet operation, low radial loads over extended portion of performance curve.

**DURABLE MOTOR WILL DELIVER MANY YEARS OF RELIABLE SERVICE**

- Oil-filled motor for maximum heat dissipation and constant bearing lubrication.
- Heat sensor thermostats imbedded in windings protect motor from overheat conditions.
- Seal leak probes warn of moisture entry; help prevent costly motor burnout.
- Double tandem shaft seals prevent sewage from entering motor.
- Power and control cables are triple sealed with epoxy, compression grommet and terminal board.

**AVAILABLE WITH OPTIONAL FM APPROVAL FOR USE IN CLASS 1, GROUP C AND D HAZARDOUS LOCATIONS (6VHX ONLY).**

**PRODUCT CAPABILITIES**

Capacities To	900 gpm	56.7 l/s
Heads To	85 ft.	25.9 m
Solids Handling	3 in.	76 mm
Liquids Handling	raw unscreened sewage, effluent, storm water	
Intermittent Liquid Temp.	up to 140°F	up to 60°C
Winding Insulation Temp. (Class H)	356°F	180°C
Available Motors	<b>1750 RPM:</b> 5–20 HP, 200, 230, 460, 575V, 3Ø, 60 Hz <b>1150 RPM:</b> 3 and 5 HP, 200, 230, 460, 575V, 3Ø, 60 Hz	
Std. Third Party Approvals	CSA	
Optional Approvals	FM, Class 1, Groups C & D (6VHX only)	
Acceptable pH Range	6 – 9	
Specific Gravity	.9 – 1.1	
Viscosity	28 – 35 SSU	
Discharge, Horizontal Flanged Centerline	6 in.	152.4 mm
	125 lb. ANSI	

NOTE: Consult factory for applications outside of these recommendations.

Construction Materials	
Motor Housing, Seal Housing, Cord Cap and Volute Case	cast iron, Class 30 ASTM A48
Enclosed 2-Vane Impeller (optional single vane)	ductile iron, Class 65 ASTM A536
Power and Control Cord	25 ft. SOOW
Mechanical Seals	double tandem, type 21
Standard	carbon and ceramic
Optional	lower tungsten, carbide
Pump, Motor Shaft	416 SST
Fasteners	300 Series SST
Volute Wear Ring	brass

**WHERE INNOVATION MEETS TRADITION**



**Myers**  
ENGINEERED PRODUCTS

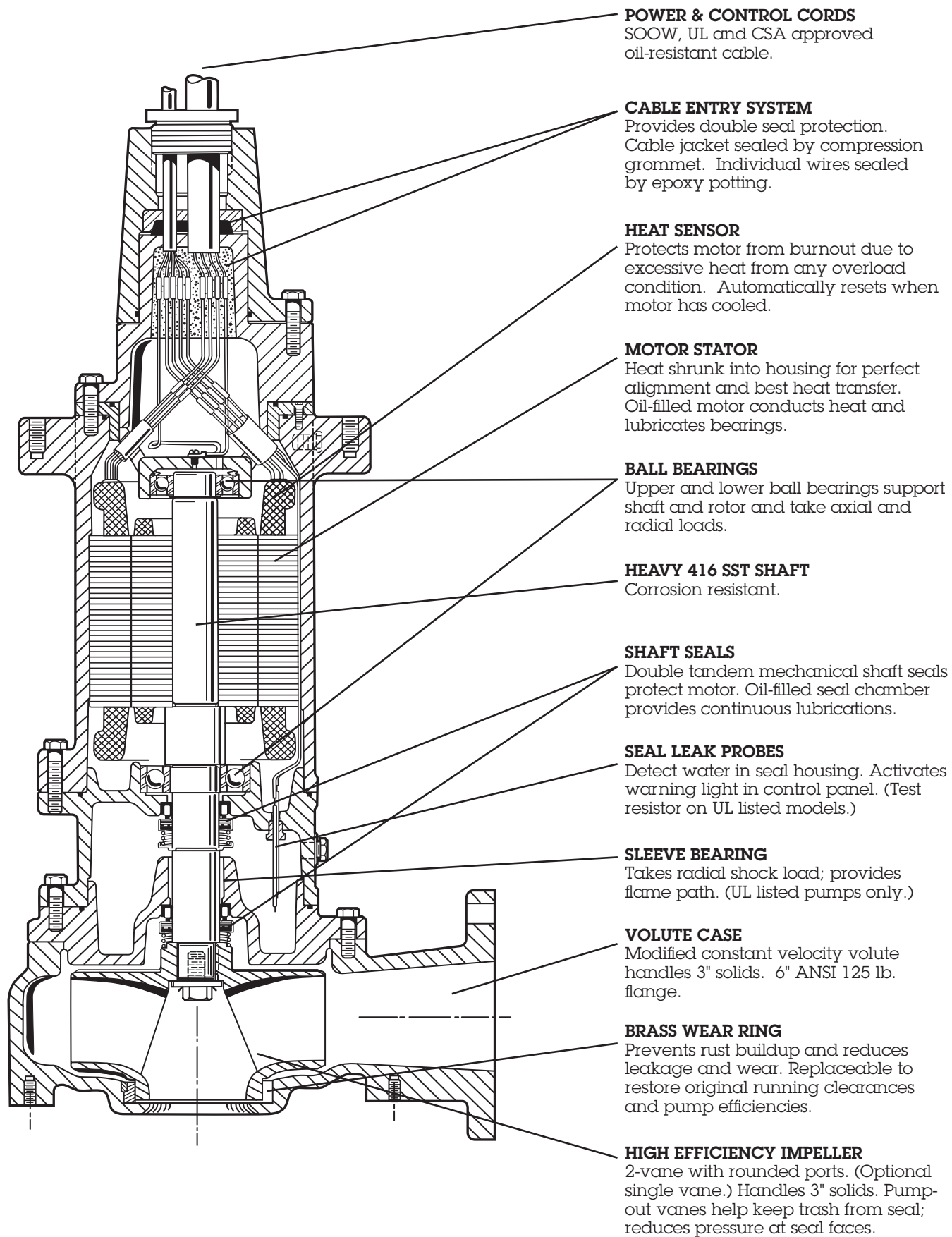

**POWER & CONTROL CORDS**  
SOOW, UL and CSA approved oil-resistant cable.

**CABLE ENTRY SYSTEM**  
Provides double seal protection. Cable jacket sealed by compression grommet. Individual wires sealed by epoxy potting.

**HEAT SENSOR**  
Protects motor from burnout due to excessive heat from any overload condition. Automatically resets when motor has cooled.

**MOTOR STATOR**  
Heat shrunk into housing for perfect alignment and best heat transfer. Oil-filled motor conducts heat and lubricates bearings.

**BALL BEARINGS**  
Upper and lower ball bearings support shaft and rotor and take axial and radial loads.

**HEAVY 416 SST SHAFT**  
Corrosion resistant.

**SHAFT SEALS**  
Double tandem mechanical shaft seals protect motor. Oil-filled seal chamber provides continuous lubrications.

**SEAL LEAK PROBES**  
Detect water in seal housing. Activates warning light in control panel. (Test resistor on UL listed models.)

**SLEEVE BEARING**  
Takes radial shock load; provides flame path. (UL listed pumps only.)

**VOLUTE CASE**  
Modified constant velocity volute handles 3" solids. 6" ANSI 125 lb. flange.

**BRASS WEAR RING**  
Prevents rust buildup and reduces leakage and wear. Replaceable to restore original running clearances and pump efficiencies.

**HIGH EFFICIENCY IMPELLER**  
2-vane with rounded ports. (Optional single vane.) Handles 3" solids. Pump-out vanes help keep trash from seal; reduces pressure at seal faces.

# PUMP PERFORMANCE

[ ] dimensions in mm

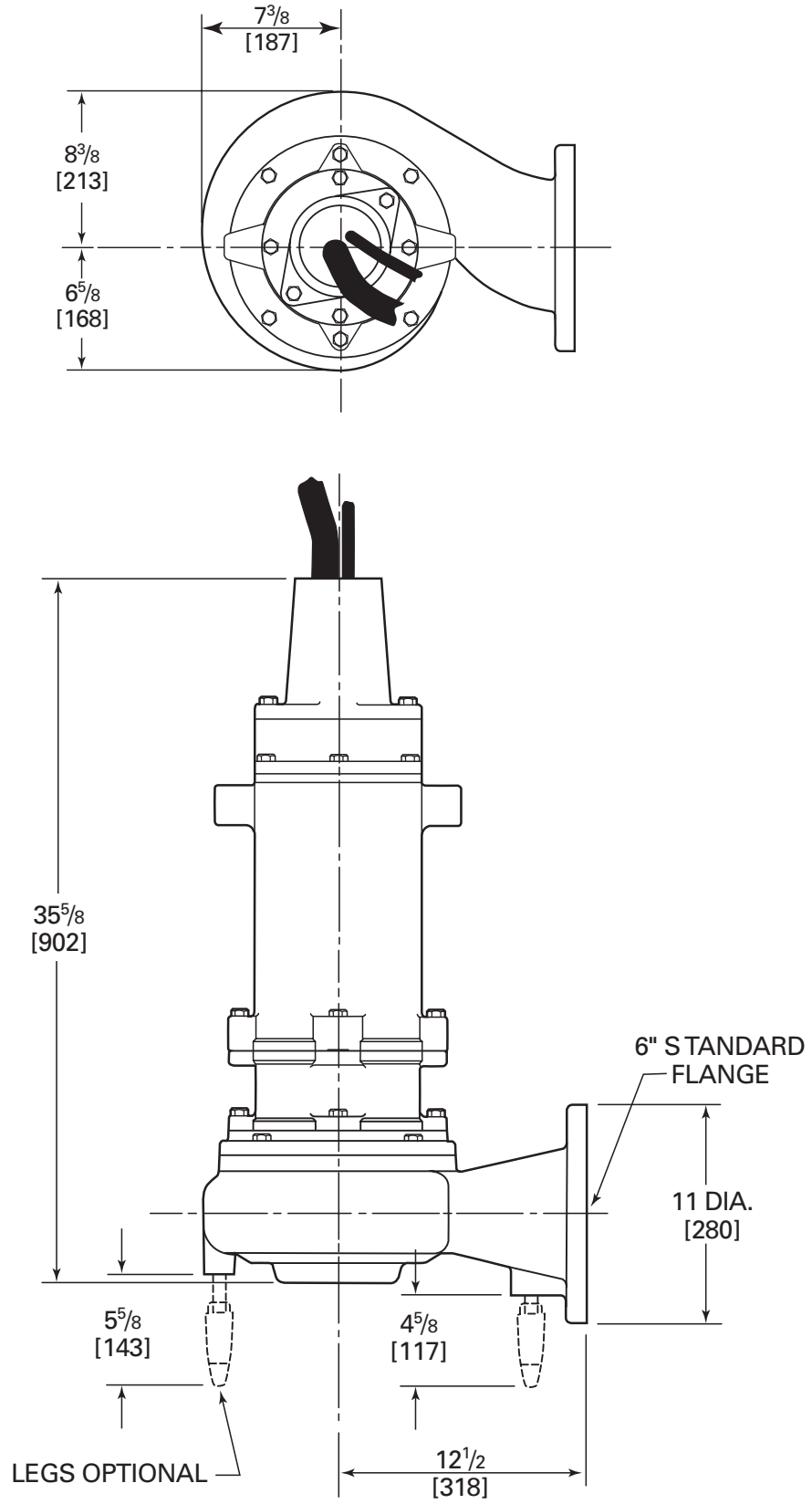

# PUMP PERFORMANCE

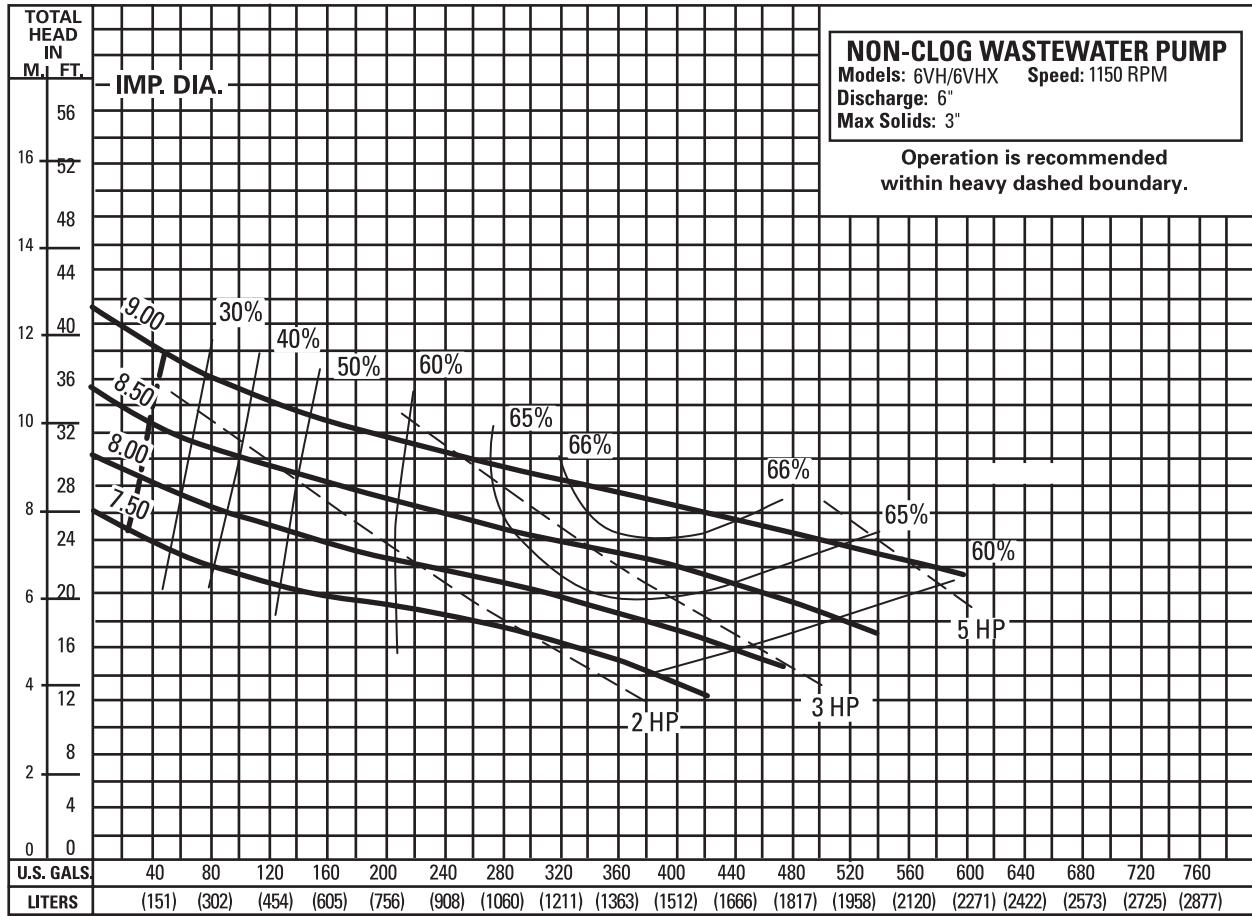

Available Models		Motor Electrical Data												
Standard	Explosion-Proof	HP	Volts	Phase	Hertz	Start Amps	Run Amps	Service Factor Amps	Run KW	Service Factor KW	Start KVA	Run KVA	NEC Code Letter	Service Factor
6VH30M6-03	6VHX30M6-03	3	200	3	60	77	15.9	19	3.3	4.3	26.7	5.5	K	1.2
6VH30M6-23	6VHX30M6-23	3	230	3	60	67	13.8	16.6	3.3	4.3	26.7	5.5	K	1.2
6VH30M6-43	6VHX30M6-43	3	460	3	60	33	7	8.3	3.3	4.3	26.7	5.5	K	1.2
6VH30M6-53	6VHX30M6-53	3	575	3	60	27	5.5	6.6	3.3	4.3	26.7	5.5	K	1.2
6VH50M6-03	6VHX50M6-03	5	200	3	60	115	24	29	5.4	6.9	39.8	8.3	J	1.2
6VH50M6-23	6VHX50M6-23	5	230	3	60	100	21	25.2	5.4	6.9	39.8	8.3	J	1.2
6VH50M6-43	6VHX50M6-43	5	460	3	60	50	10.5	12.6	5.4	6.9	39.8	8.3	J	1.2
6VH50M6-53	6VHX50M6-53	5	575	3	60	40	8.3	10	5.4	6.9	39.8	8.3	J	1.2

Motor Efficiencies and Power Factor											
		Motor Efficiency %					Power Factor %				
HP	Phase	Service Factor Load	100%	75%	50%	Service Factor Load	100%	75%	50%		
			Load	Load	Load		Load	Load	Load		
3	3	73	72	68	58.5	66	61	53.5	44		
5	3	74	73	69.5	64	68.5	65	59	48.5		

# PUMP PERFORMANCE

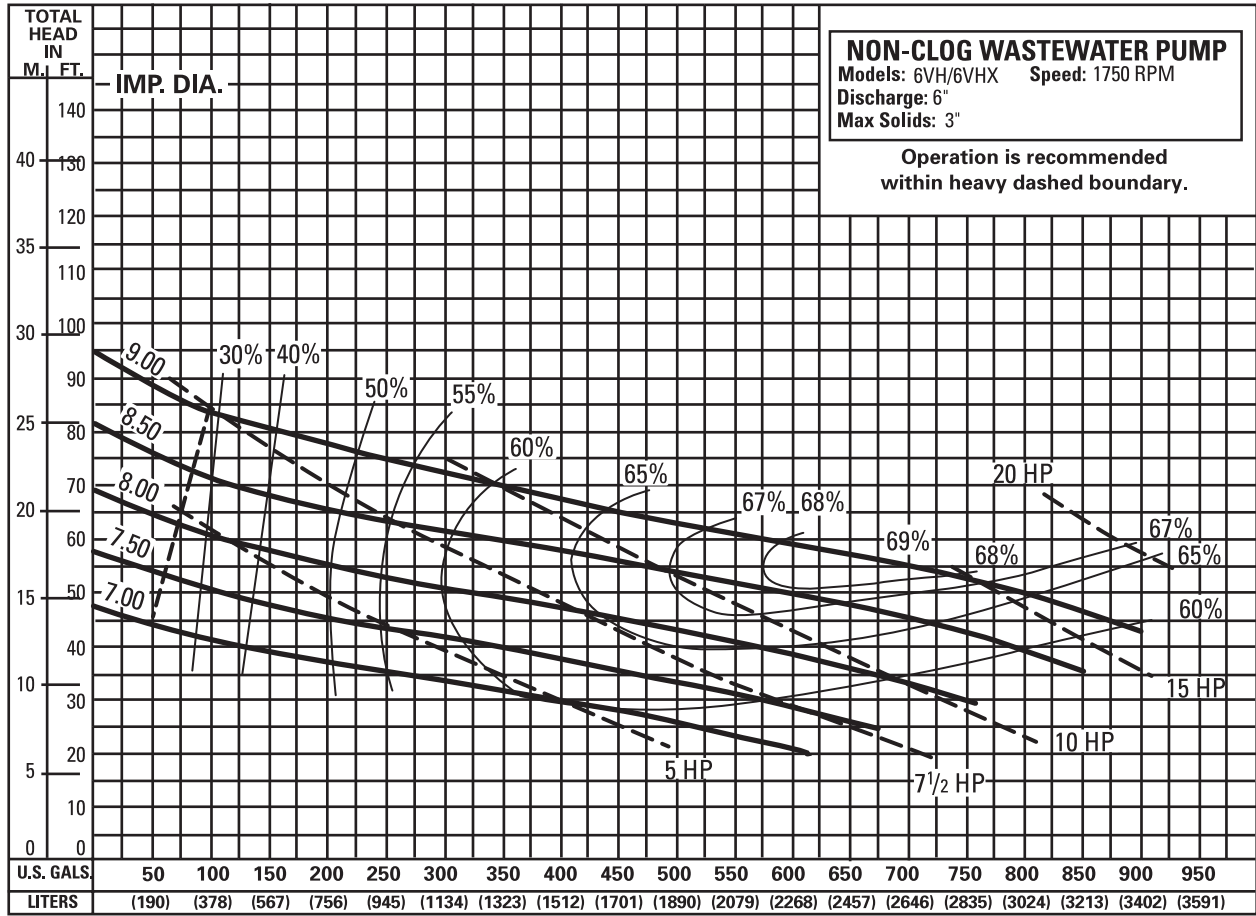

Available Models		Motor Electrical Data												
Standard	Explosion-Proof	HP	Volts	Phase	Hertz	Start Amps	Run Amps	Service Factor Amps	Run KW	Service Factor KW	Start KVA	Run KVA	NEC Code Letter	Service Factor
6VH50M4-03	6VHX50M4-03	5	200	3	60	115	21	25.3	5.7	7.2	30.0	7.2	J	1.2
6VH50M4-23	6VHX50M4-23	5	230	3	60	100	18	22	5.7	7.2	39.9	7.2	J	1.2
6VH50M4-43	6VHX50M4-43	5	460	3	60	50	9	11	5.7	7.2	39.9	7.2	J	1.2
6VH50M4-53	6VHX50M4-53	5	575	3	60	40	7.2	8.8	5.7	7.2	39.9	7.2	J	1.2
6VH75M4-03	6VHX75M4-03	7.5	200	3	60	153	30	36.8	8.3	10.4	53.0	10.0	H	1.2
6VH75M4-23	6VHX75M4-23	7.5	230	3	60	133	26	32	8.3	10.4	53.0	10.0	H	1.2
6VH75M4-43	6VHX75M4-43	7.5	460	3	60	66	13	16	8.3	10.4	53.0	10.0	H	1.2
6VH75M4-53	6VHX75M4-53	7.5	575	3	60	53	10	12.8	8.3	10.4	53.0	10.0	H	1.2
6VH100M4-03	6VHX100M4-03	10	200	3	60	204	40	48.3	11.3	13.9	70.7	13.9	H	1.2
6VH100M4-23	6VHX100M4-23	10	230	3	60	178	35	42	11.3	13.9	70.7	13.9	H	1.2
6VH100M4-43	6VHX100M4-43	10	460	3	60	89	17.5	21	11.3	13.9	70.7	13.9	H	1.2
6VH100M4-53	6VHX100M4-53	10	575	3	60	71	14	16.8	11.3	13.9	70.7	13.9	H	1.2
6VH150M4-03	6VHX150M4-03	15	200	3	60	272	60	72	16.4	20.4	94.0	20.8	G	1.2
6VH150M4-23	6VHX150M4-23	15	230	3	60	236	52	60	16.4	20.4	94.0	20.8	G	1.2
6VH150M4-43	6VHX150M4-43	15	460	3	60	118	26	30	16.4	20.4	94.0	20.8	G	1.2
6VH150M4-53	6VHX150M4-53	15	575	3	60	94	21	25.5	16.4	20.4	94.0	20.8	G	1.2
6VH200M4-23		20	230	4	60	236	60	60	20.4	20.4	94.0	25.5	E	1.0
6VH200M4-43		20	460	3	60	118	30	30	20.4	20.4	94.0	25.5	E	1.0
6VH200M4-53		20	575	3	60	94	25.5	25.5	20.4	20.4	94.0	25.5	E	1.0

Motor Efficiencies and Power Factor									
Motor Efficiency %						Power Factor %			
HP	Phase	Service Factor Load	100%	75%	50%	Service Factor Load	100%	75%	50%
			Load	Load	Load		Load	Load	Load
5	3	72	73	70.5	64	82	80	76	66.5
7.5	3	78	77	74	67.5	81.5	80	75.5	68
10	3	80	80	77	70.5	83	81.5	75.5	67
15	3	78.5	80	79.5	74.5	82	79	72	61
20	3	77	77	80	78	82.5	82.5	79	69

# 6VH and 6VHX

## SPECIFICATIONS

**PUMP MODEL** – Pump shall be Myers Model Number 6VH / 6VHX Non-Clog Submersible Pump with 2-vane enclosed impeller. All openings in pump impeller and volute case shall be large enough to pass a 3" diameter sphere. Discharge flange shall be six (6) inch standard. Pump and motor assembly shall be UL listed for Class 1, Group D explosion-proof service (6VHX only).

**OPERATING CONDITIONS** – Pump shall have a capacity of \_\_\_\_\_ GPM at a total head of \_\_\_\_\_ feet and shall use a \_\_\_\_\_ HP motor operating at \_\_\_\_\_ RPM.

**MOTOR** – Pump motor shall be of the sealed submersible type rated \_\_\_\_\_ HP at \_\_\_\_\_ RPM 60 Hertz. Motor shall be for three phase 200 volts \_\_\_\_\_, 230 volts \_\_\_\_\_, 460 volts \_\_\_\_\_, or 575 volts \_\_\_\_\_. Motor shall be NEMA B type.

Stator winding shall be of the open type with Class H insulation good for 180°C (356°F) maximum operating temperature. Winding housing shall be filled with a clean high dielectric oil that lubricates bearings and seals and transfers heat from windings and rotor to outer shell. Air-filled motors that do not have the superior heat dissipating capabilities of oil-filled motors shall not be considered equal.

Motor shall have two heavy duty ball bearings to support pump shaft and take radial and thrust loads and a sleeve guide bushing directly above the lower seal to take radial load and act as flame path for seal chamber. Ball bearings shall be designed for 50,000 hours B-10 life. Stator shall be heat shrunk into motor housing.

A heat sensor thermostat shall be attached to and imbedded in the winding and be connected in series with the motor starter contactor coil to stop motor if temperature of winding is more than 120°C (248°F). Thermostat to reset automatically when motor cools to safe operating temperature. Three heat sensors to be used on 3 phase motors. The common pump, motor shaft shall be of 416 stainless steel.

**SEALS** – Motor shall be protected by two mechanical seals mounted in tandem with a seal chamber between the seals. Seal chamber shall be oil filled to lubricate seal face and to transmit heat from shaft to outer shell.

Seal face shall be carbon and ceramic and lapped to a flatness of one light band. Lower seal faces shall be \_\_\_\_\_ carbide (optional).

A double electrode shall be mounted in the seal chamber to detect any water entering the chamber through the lower seal. Water in the chamber shall cause a red light to turn on at the control box. This signal shall not stop motor but shall act as a warning only, indicating service is required.

**IMPELLER** – The impeller shall be cast ductile iron and of the 2-vane non-clog enclosed type. Vane inlet tips shall be carefully rounded to prevent stringy material from catching in vanes. Pump-out vane shall be used in front and back chamber. Impeller shall be dynamically balanced. Impeller shall be driven by stainless steel shaft key and impeller held in place with lock screw and washer. Impeller and motor shall lift off of case as a unit without disturbing discharge piping.

**PUMP CASE** – The volute case shall be cast iron and have a flanged center line discharge. Discharge flange shall be 6" standard with bold holes straddling center line. A bronze wear ring shall be pressed into case for guiding impeller neck and to prevent corrosion freeze-up. Wear ring shall be held from rotating by locking with stainless steel set screw in end of ring.

**PUMP AND MOTOR CASTING** – All castings shall be of high tensile cast iron and shall be treated with phosphate and chromate rinse. All fasteners shall be 302 stainless steel.

**BEARING END CAP** – Upper motor bearing cap shall be a separate casting for easy mounting and replacement.

**POWER CABLES** – Power cord and control cord shall be double sealed. The power and control conductor shall be single strand sealed with epoxy potting compound and then clamped in place with rubber seal bushing to seal outer jacket against leakage and to provide for strain pull. Cords shall withstand a pull of 300 pounds to meet UL requirements.

Insulation of power and control cords shall be type SOOW. Both control and power cords shall have a green carrier ground conductor which attaches to motor frame.